

Passes câbles

Cable bushings / Polished and shiny brass or chromed brass

Laiton poli brillant et laiton chromé.

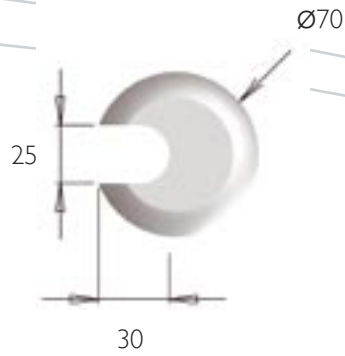
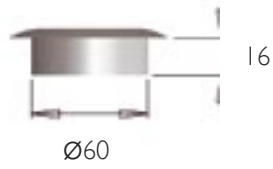

Ligne Gypse
Passes câbles
Cable bushings

Laiton : I D 03 07 (7,5 points)

Laiton chromé : I D 03 08 (8 points)

